

INSTRUCTIONS:

1. SLIDE CAP AND RETAINING RING ON GEAR WIRE.
2. ASSEMBLE 2 HALVES OF STRUT COVER OVER GEAR WIRE.
3. SLIDE RING, THEN CAP OVER GEAR STRUT AS SHOWN AND INSTALL SCREWS.
4. INSTALL HUB DETAIL AND WHEEL SPACER.
5. USE PLASTI-ZAP TO SECURE PARTS.
6. CUSTOMIZE WITH CHROME MYLAR/MONOKOTE® AND PAINT.

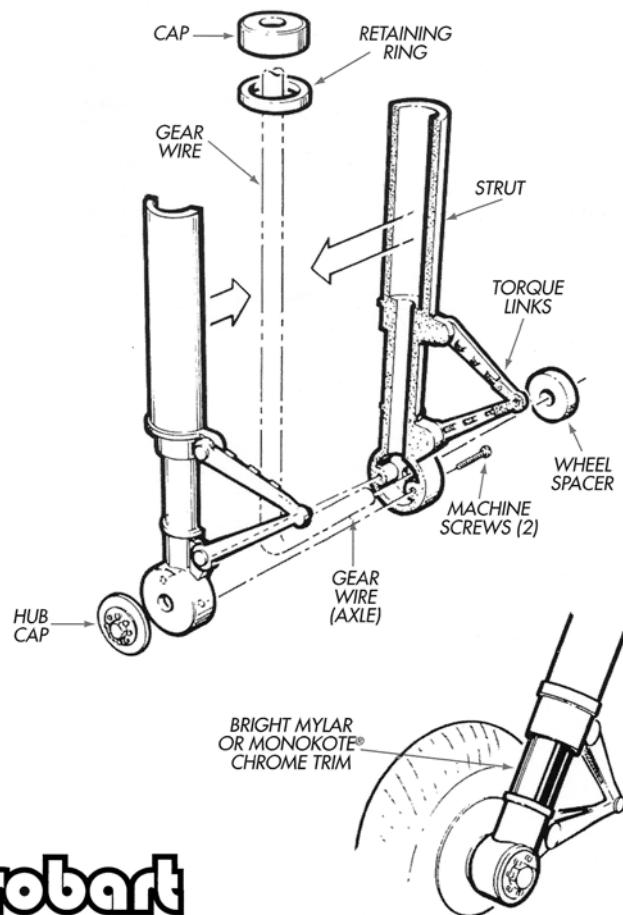

robart
625 N. 12TH STREET
ST. CHARLES, IL 60174
PHONE: 630-584-7616
WEB SITE: www.robart.com

FOR FURTHER INFO VISIT
www.robart.com/support and DOWNLOAD
SCALE STRUT COVERS HOW-TO