

** THIS IS YOUR SPARE PARTS LIST. SAVE FOR FUTURE REFERENCE, ORDER BY PART NUMBER. CURRENT PRICES WILL BE QUOTED.**

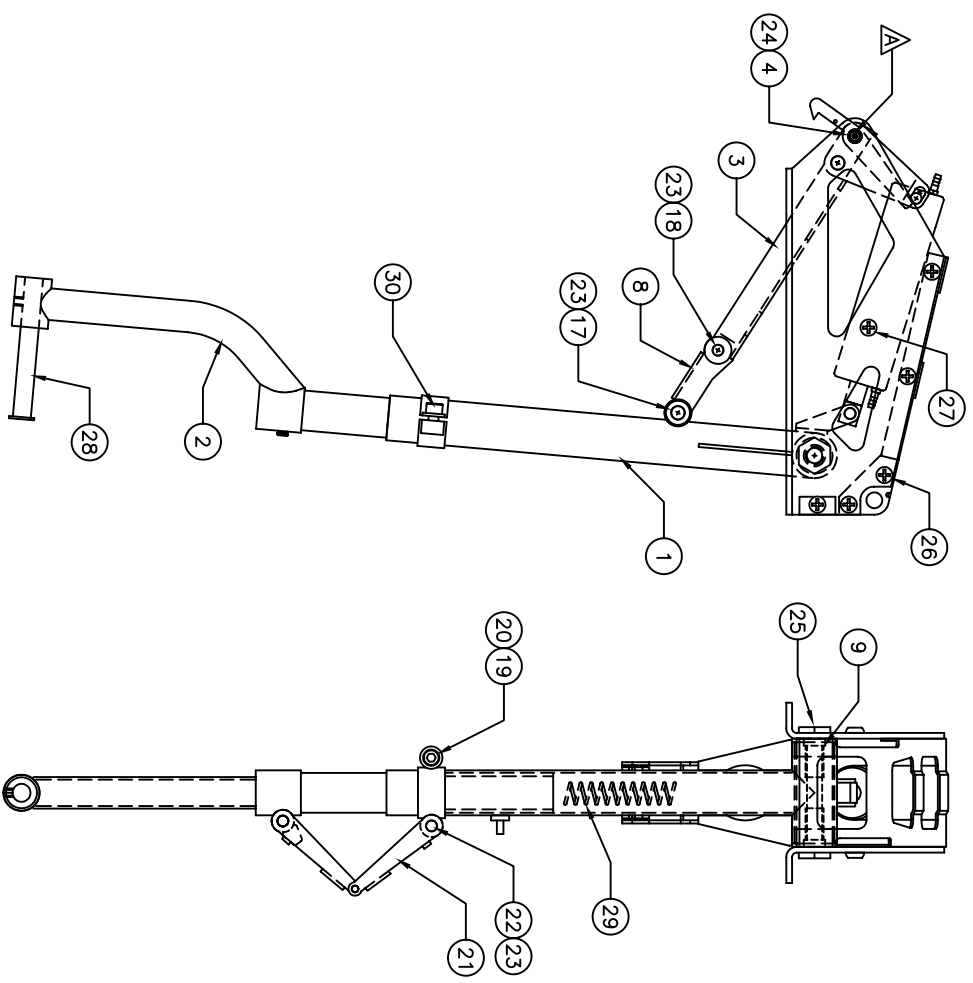
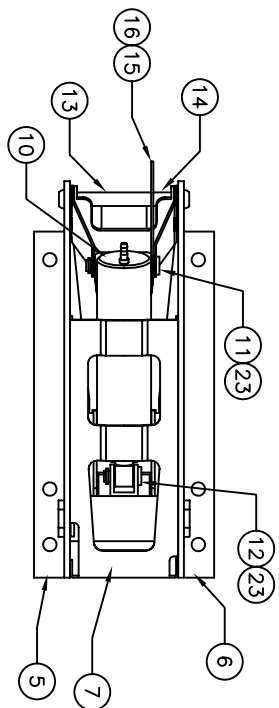

SPARE PARTS LIST

QTY	ITEM	DESCRIPTION	ASS'Y/PART #
1	1	TRUNION ASSEMBLY	152-104A
1	2	OLEO RAM RH/LH	145-225A RH / 145-224A LH
1	3	LIFT YOKE ASSEMBLY	150-105A
1	4	LIFT YOKE PIVOT PIN	150-004M
1	5	SIDE FRAME (RH)	150-037M
1	6	SIDE FRAME (LH)	150-036M
1	7	SPACER BRACKET	150-038M
1	8	LIFT LINK	150-029M
1	9	TRUNION SHAFT	151-007M
1	10	CYLINDER ASSEMBLY	150-108A
1	11	CYLINDER CLEVIS PIN	150-012M
1	12	ACTUATOR CLEVIS PIN	150-018M
1	13	LATCH SPACER TUBE LARGE	150-001M
1	14	LATCH SPACER TUBE SMALL	150-005M
1	15	LATCH PAWL	150-003M
1	16	LATCH SPRING	102-008M
1	17	LIFT LINK CLEVIS PIN	150-010M
2	18	LIFT YOKE CLEVIS PIN	150-033M
1	19	TORQUE LINK MOUNT RH	150-112A
1	20	TORQUE LINK MOUNT LH	150-113A
1	21	TORQUE LINK ASSEMBLY	150-107A
2	22	CLEVIS PIN (CAM PIN)	150-002M
7	23	RETAINING RING	1039F
2	24	#4-40 x 1/4 BHCS	1022F
2	25	HEX SHOULDER BOLT 1/4-28	151-008M
10	26	#4 X 1/4 PPHMS	1026F
1	27	#6 PPHSMS	1012F
1	28	AXLE BAG	145-142A
1	29	SPRING	151-019P
1	30	10-32 x 1/2" SHCS BLACK	1072F

▲ NOTE THAT OLD STYLE PIVOT PINS DO NOT HAVE THE STEPPED ENDS AS THE NEW STYLE. TO CONVERT THE SIDE FRAMES TO ACCEPT THE NEW STYLE PIN THE PIN MOUNTING HOLES HAVE TO BE DRILLED OUT WITH A #24 DRILL (0.152)

CHK'D BY			MFG. INC. 625 N. 12TH ST. ST. CHARLES, IL (630)584-7616
DRAWN BY	J. REHAK		
DATE	6-18-02	TITLE	90° NON ROTATING OFFSET LARGE SCALE RETRACTS
MODEL No.	154		

906-024M
FACTORY REPAIR FEE= \$25.00 PLUS PARTS