

REVISIONS			
REV.	DESCRIPTION	DATE	APPROVED

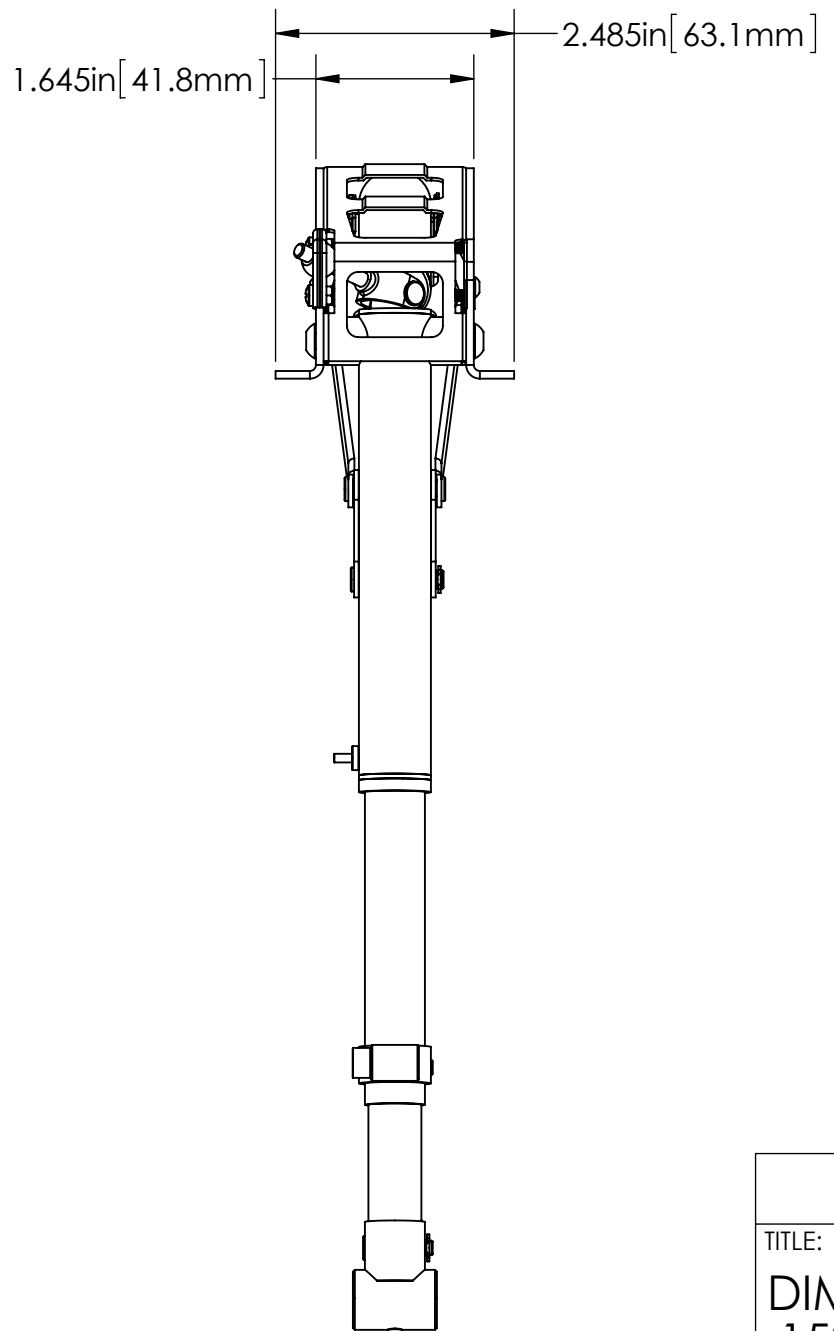
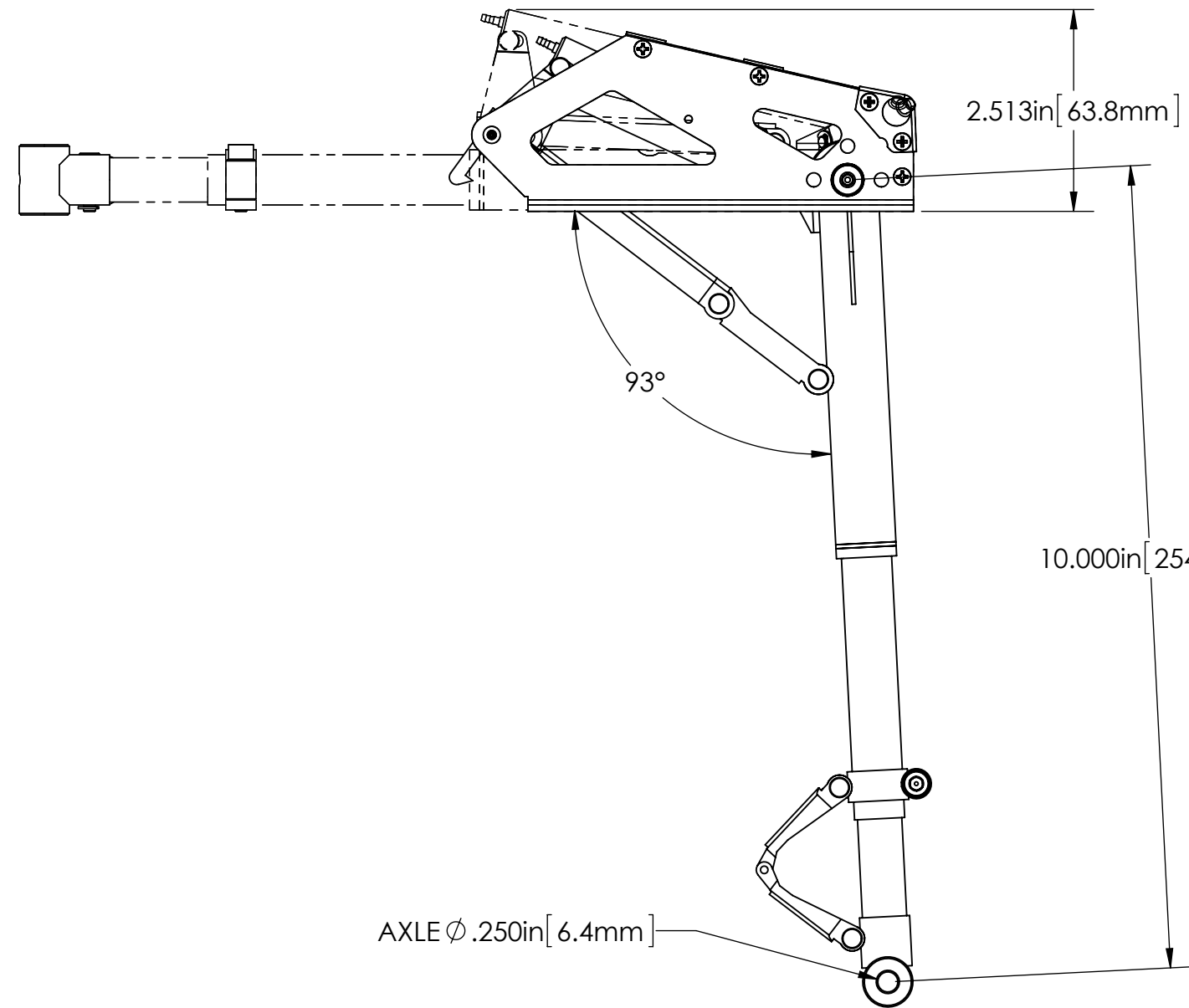
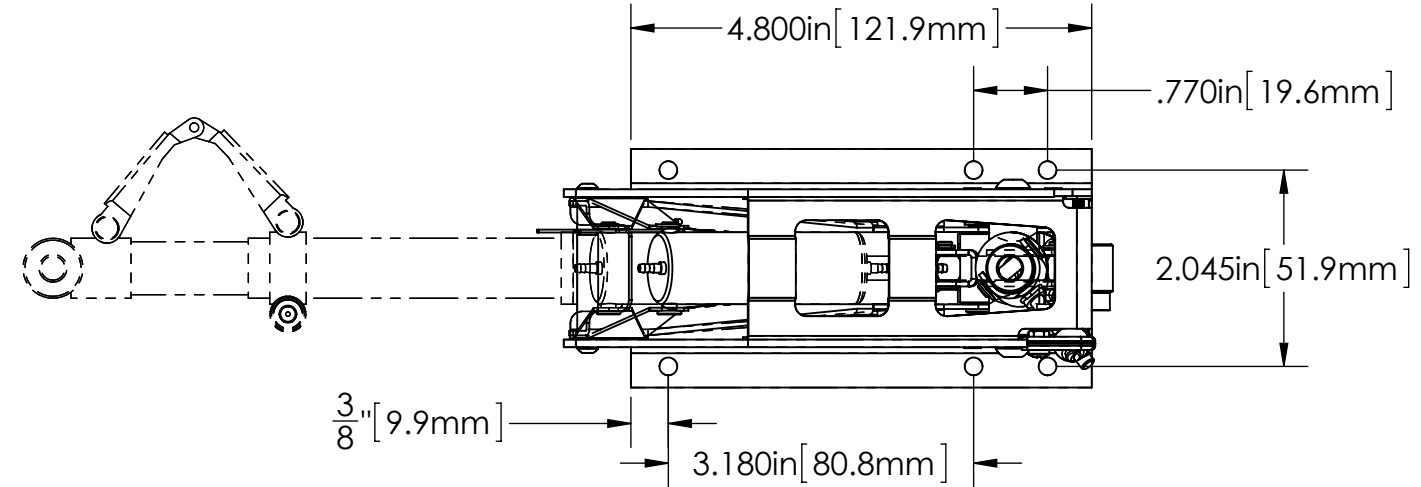

**UNITS:**  
INCH [mm]

ROBART MFG.		
TITLE: DIMENSIONAL DETAILS 150HD10 MAIN GEAR		
SIZE <b>B</b>	DWG. NO. 150HD10 DIM	REV -
SCALE: 1:2	WEIGHT:	SHEET 1 OF 1

<b>PROPRIETARY AND CONFIDENTIAL</b> THE INFORMATION CONTAINED IN THIS DRAWING IS THE SOLE PROPERTY OF ROBART MANUFACTURING. ANY REPRODUCTION IN PART OR AS A WHOLE WITHOUT THE WRITTEN PERMISSION OF ROBART MANUFACTURING IS PROHIBITED.	UNLESS OTHERWISE SPECIFIED: DIMENSIONS ARE IN INCHES TOLERANCES: FRACTIONAL ± 1/32 ANGULAR: MACH ± 1° BEND ± 1° TWO PLACE DECIMAL ± 0.01 THREE PLACE DECIMAL ± 0.005 FOUR PLACE DECIMAL ± 0.0005	DRAWN	NAME	DATE
	CHECKED	N.MARC	6/1/15	
	MFG APPR.			
	Q.A.			