

REVISIONS			
REV.	DESCRIPTION	DATE	APPROVED
1			

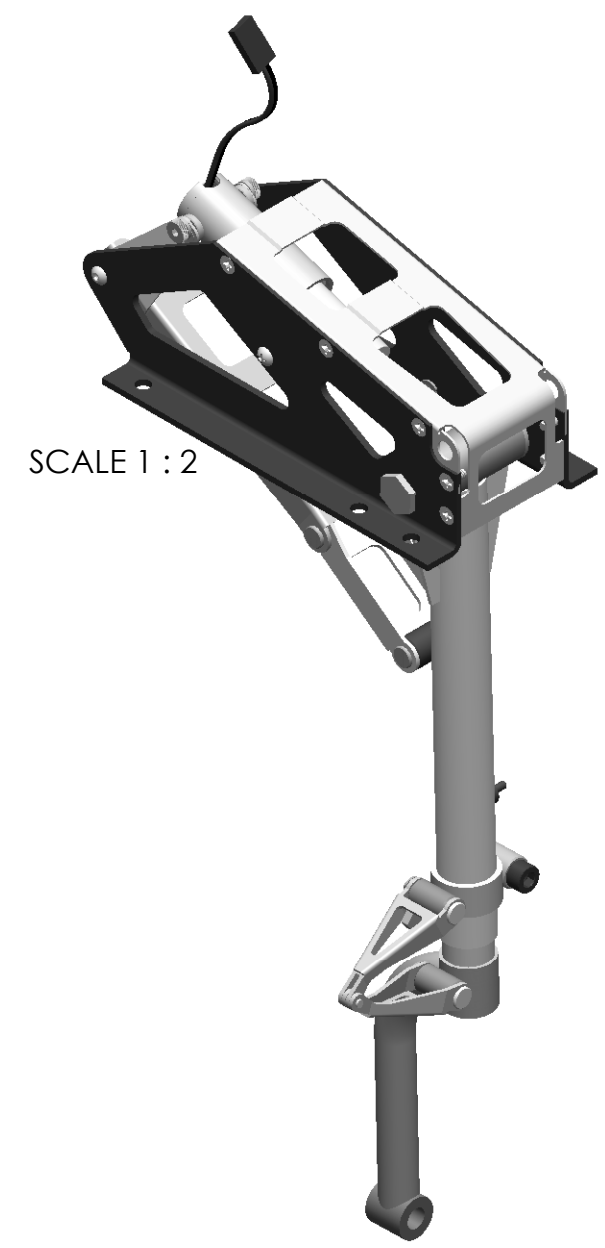
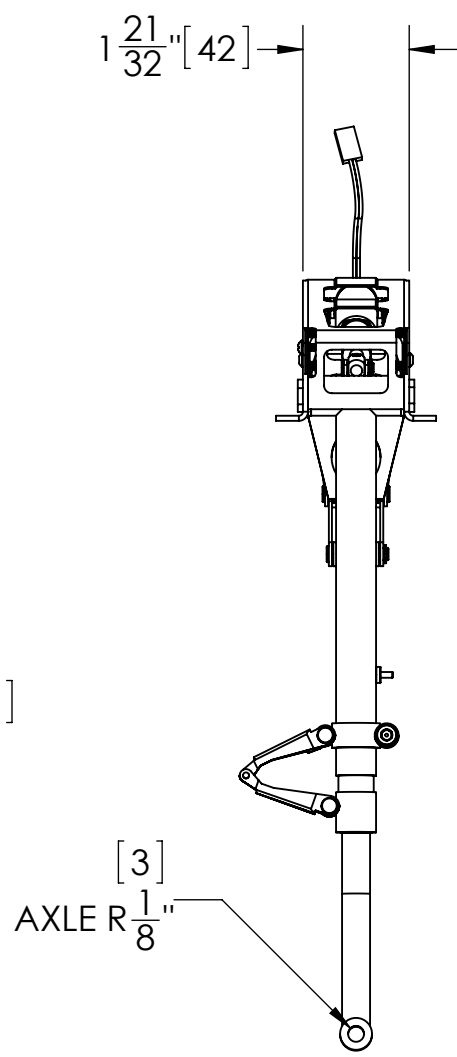
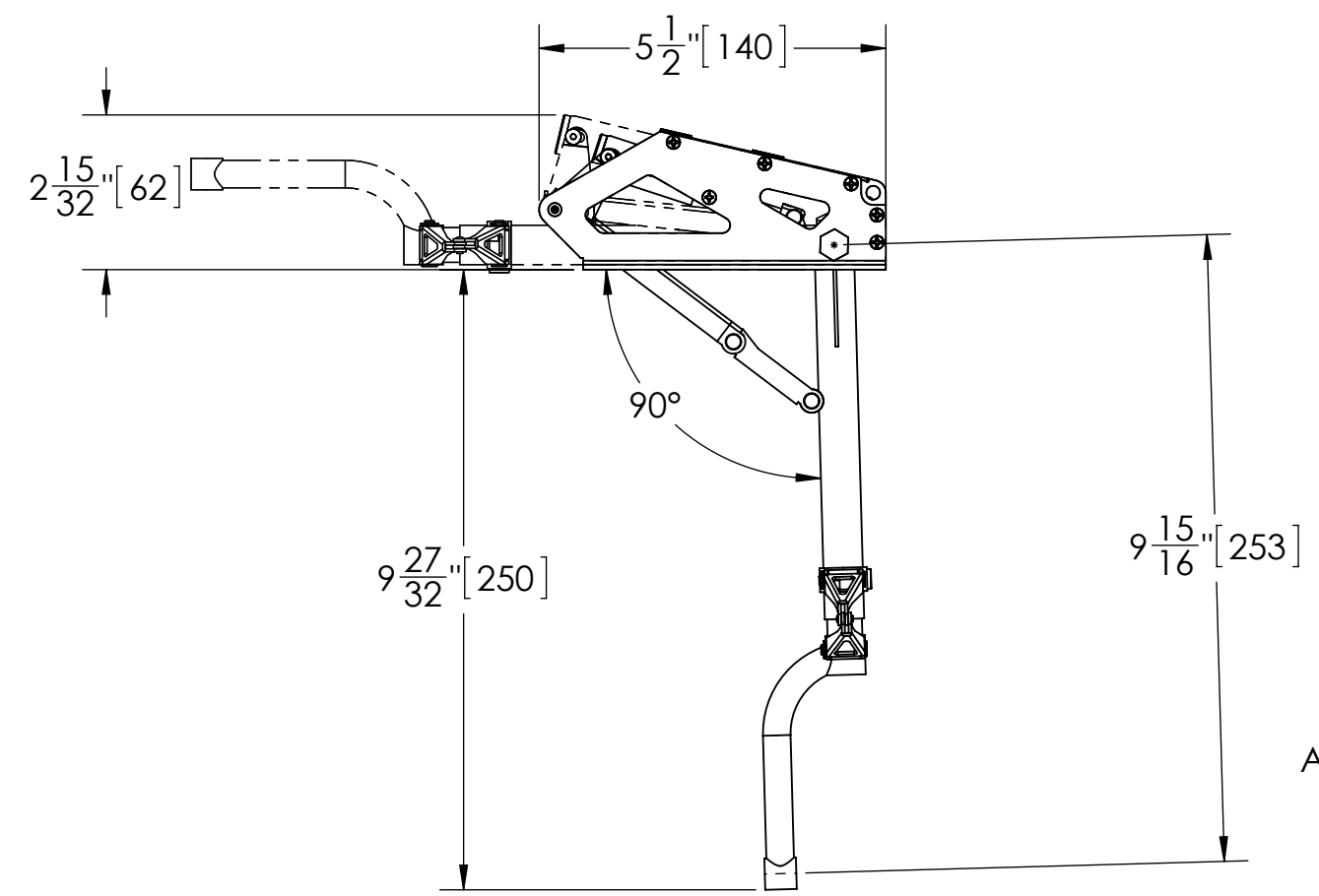
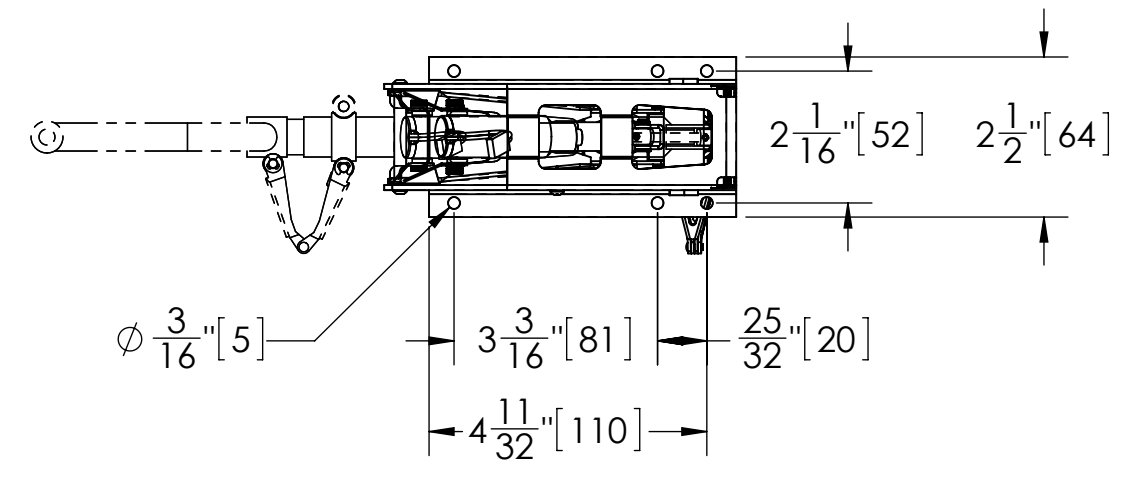

**UNITS:**  
INCH [mm]

ROBART MFG.		
TITLE: 153 ELECTRIC MAIN GEAR DIM DETAILS		
SIZE <b>B</b>	DWG. NO. <b>153E DIM</b>	REV -
SCALE: 1:2	WEIGHT:	SHEET 1 OF 1

<b>PROPRIETARY AND CONFIDENTIAL</b> THE INFORMATION CONTAINED IN THIS DRAWING IS THE SOLE PROPERTY OF ROBART MANUFACTURING. ANY REPRODUCTION IN PART OR AS A WHOLE WITHOUT THE WRITTEN PERMISSION OF ROBART MANUFACTURING IS PROHIBITED.	UNLESS OTHERWISE SPECIFIED:		NAME	DATE
	DIMENSIONS ARE IN INCHES	DRAWN	N.MARC	7JUL14
	TOLERANCES:	CHECKED		
	FRACTIONAL $\pm 1/32$	MFG APPR.		
ANGULAR: MACH $\pm 1^\circ$	Q.A.			
BEND $\pm 1^\circ$				
TWO PLACE DECIMAL $\pm 0.01$				
THREE PLACE DECIMAL $\pm 0.005$				
FOUR PLACE DECIMAL $\pm 0.0005$				