

REVISIONS			
REV.	DESCRIPTION	DATE	APPROVED

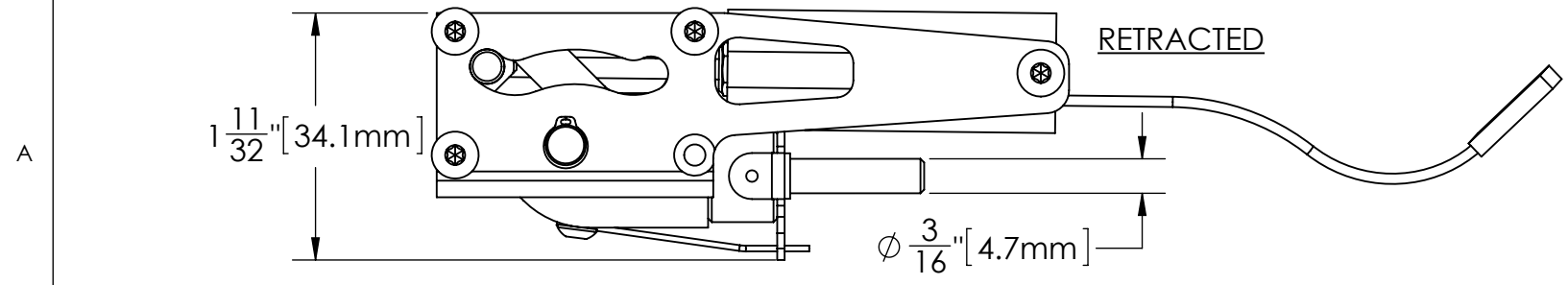
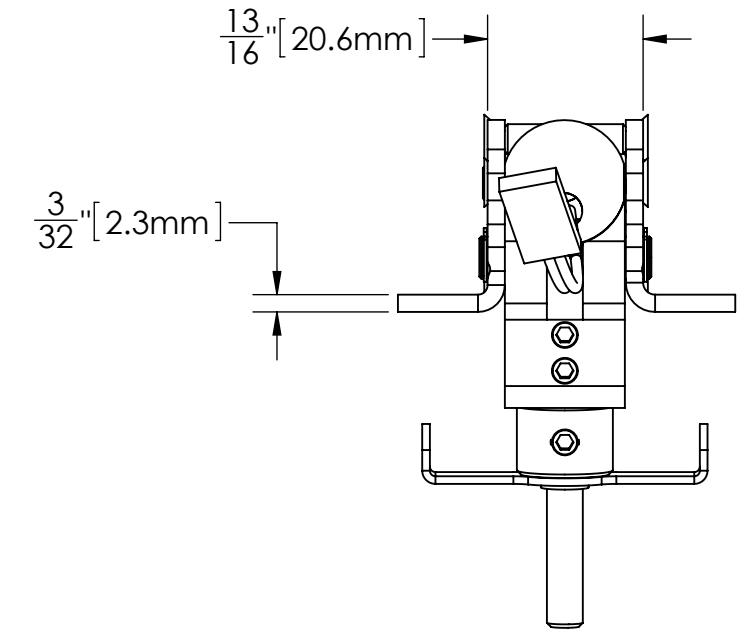
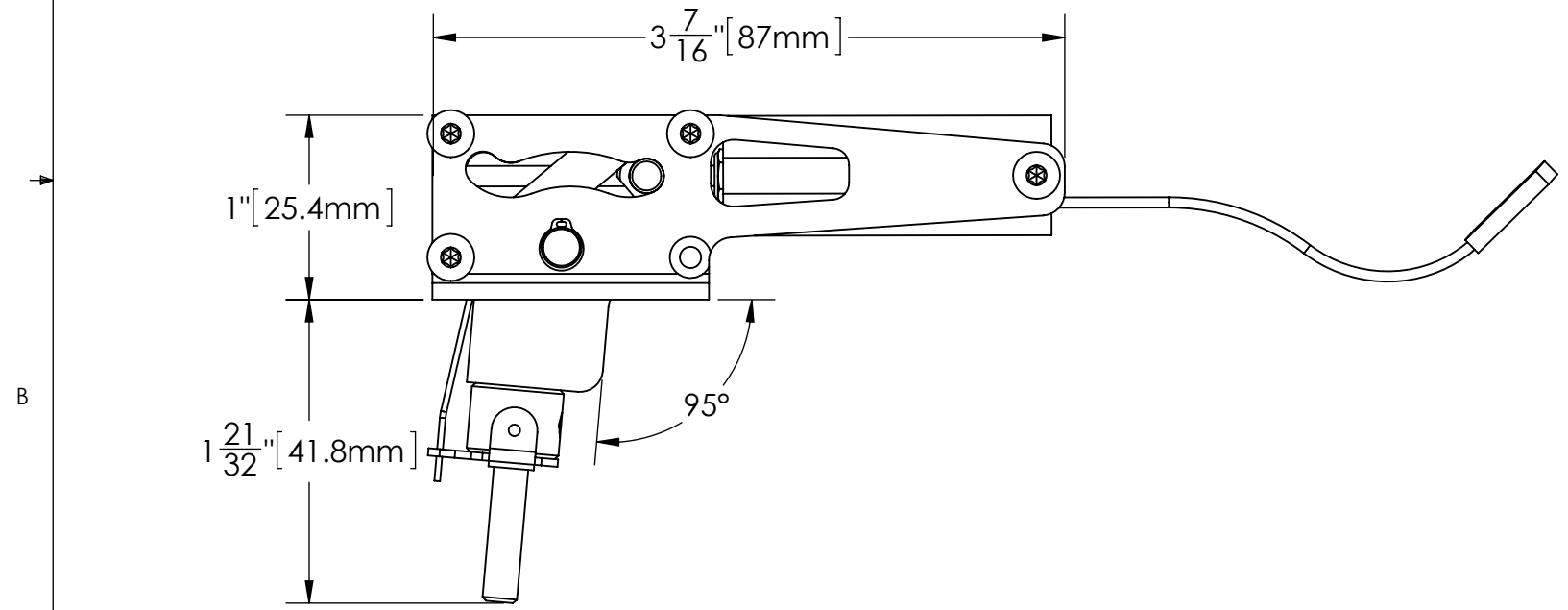
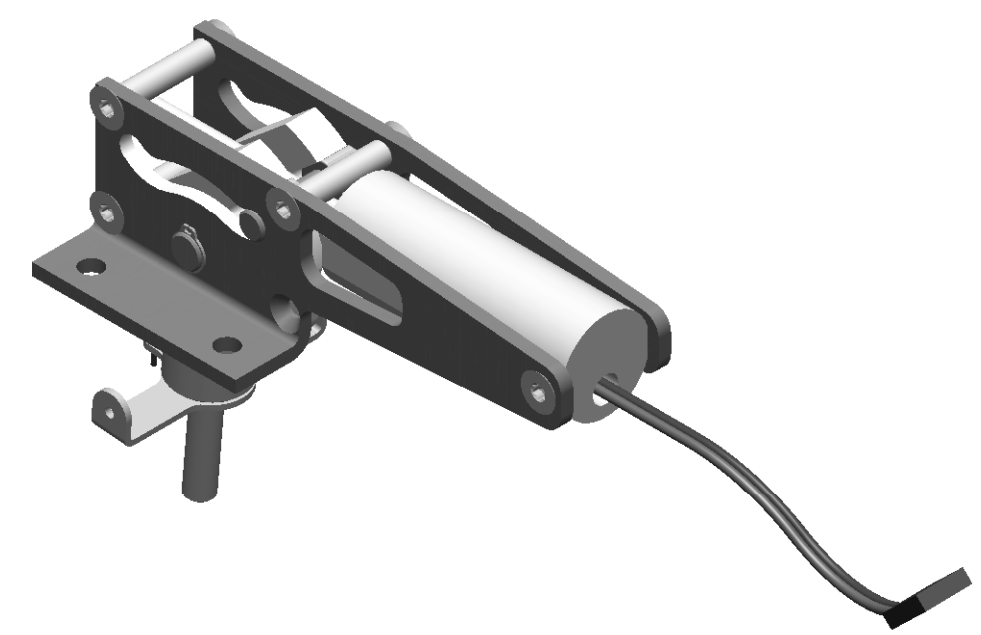
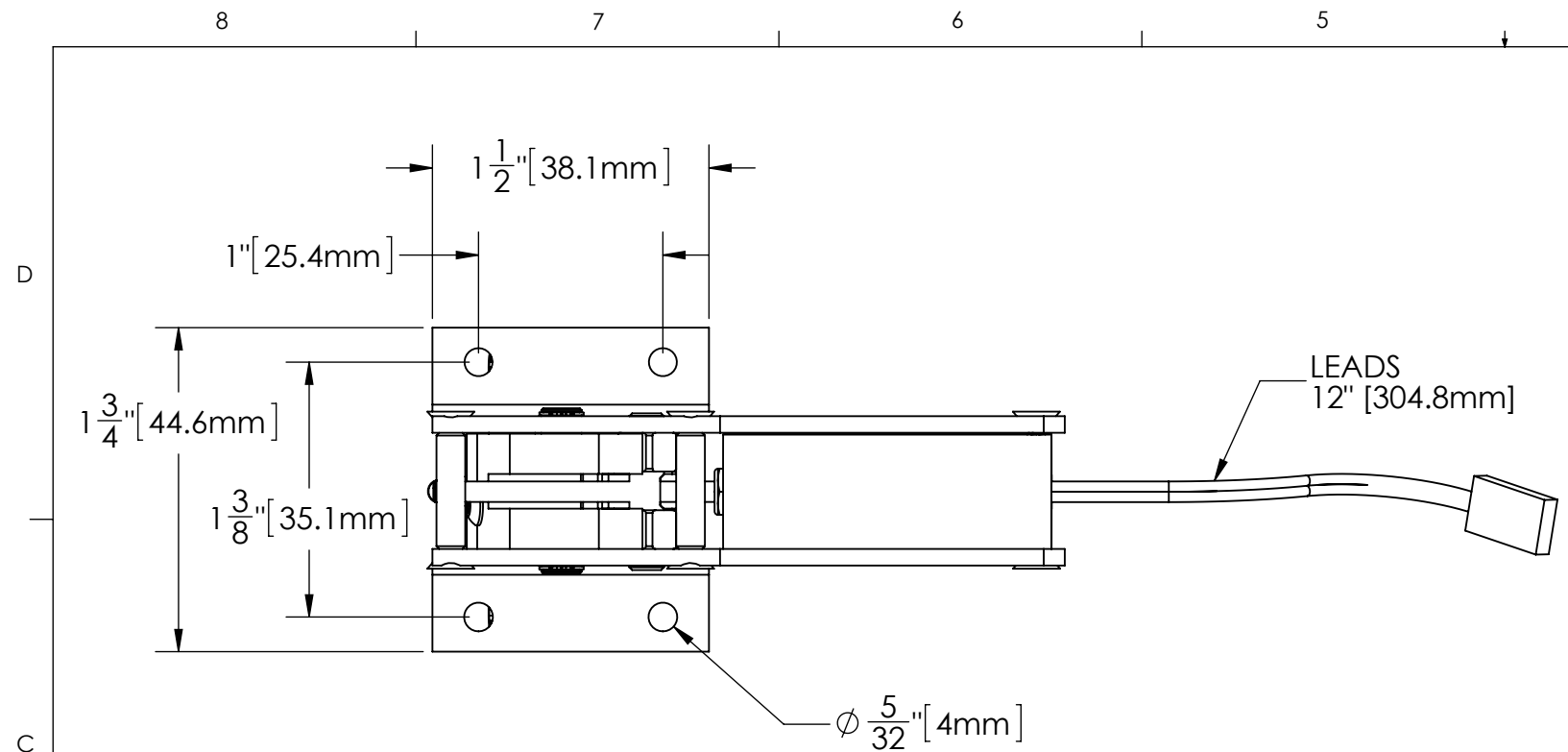

<b>PROPRIETARY AND CONFIDENTIAL</b> THE INFORMATION CONTAINED IN THIS DRAWING IS THE SOLE PROPERTY OF ROBERT MANUFACTURING. ANY REPRODUCTION IN PART OR AS A WHOLE WITHOUT THE WRITTEN PERMISSION OF ROBERT MANUFACTURING IS PROHIBITED.	UNLESS OTHERWISE SPECIFIED: DIMENSIONS ARE IN INCHES TOLERANCES: FRACTIONAL $\pm$ 1/32 ANGULAR: MACH $\pm$ 1° BEND $\pm$ 1° TWO PLACE DECIMAL $\pm$ 0.01 THREE PLACE DECIMAL $\pm$ 0.005 FOUR PLACE DECIMAL $\pm$ 0.0005	DRAWN	N.MARC	DATE	22JUL14
		CHECKED			
		MFG APPR.			
		Q.A.			

ROBART MFG.		
TITLE: DIMENSIONAL DETAIL 556RSE		
SIZE <b>B</b>	DWG. NO. 556RSE DIM	REV -
SCALE: 1:1	WEIGHT:	SHEET 1 OF 1