

REVISIONS			
REV.	DESCRIPTION	DATE	APPROVED

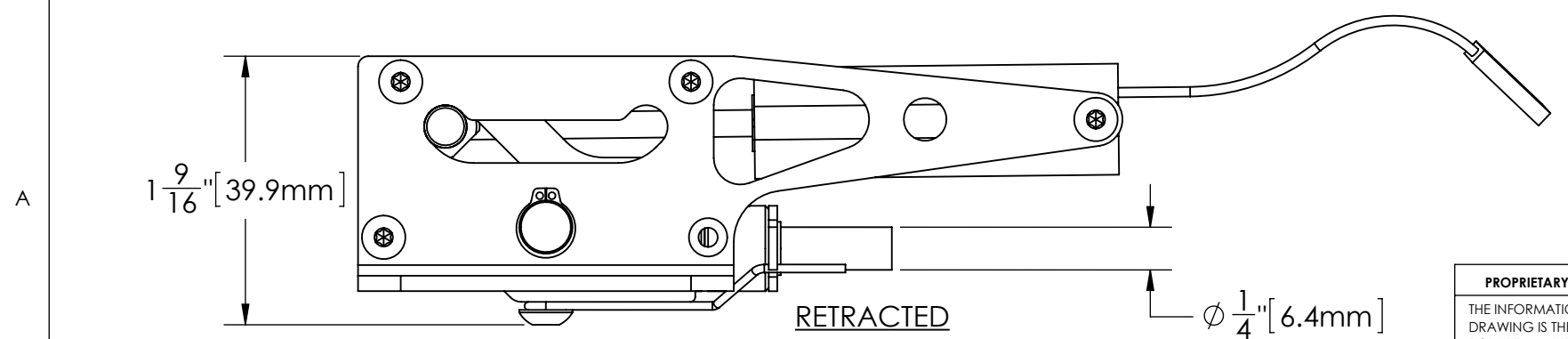
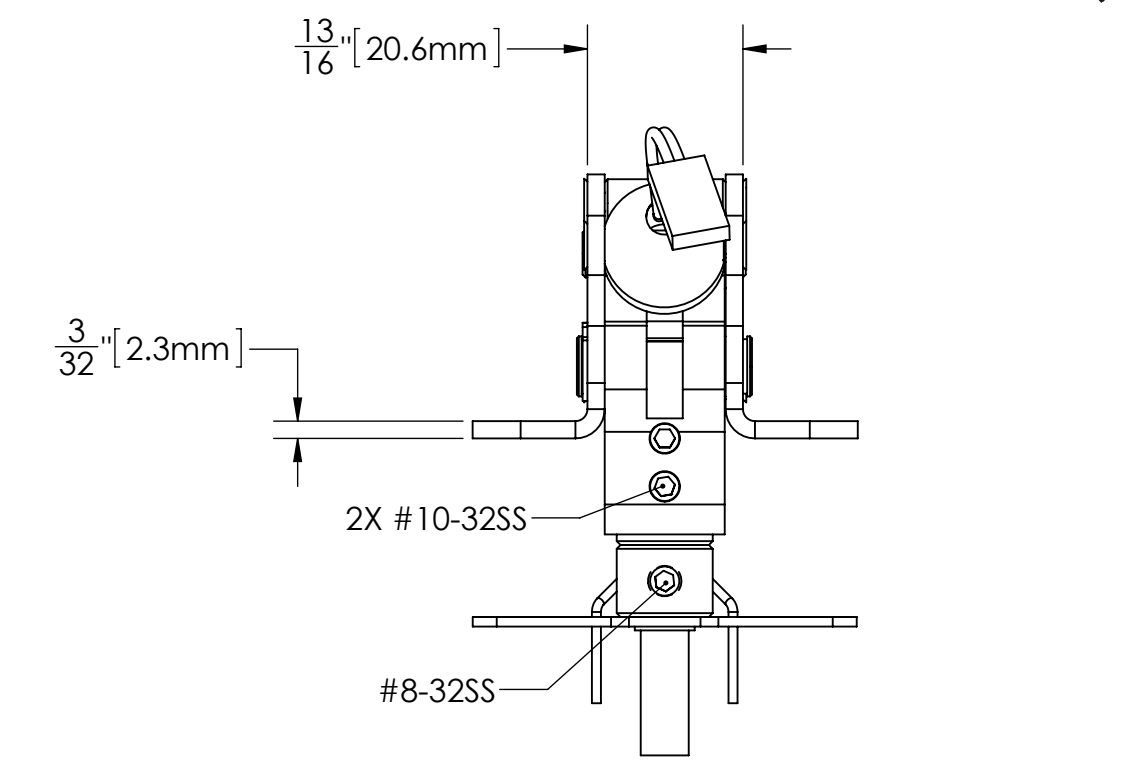
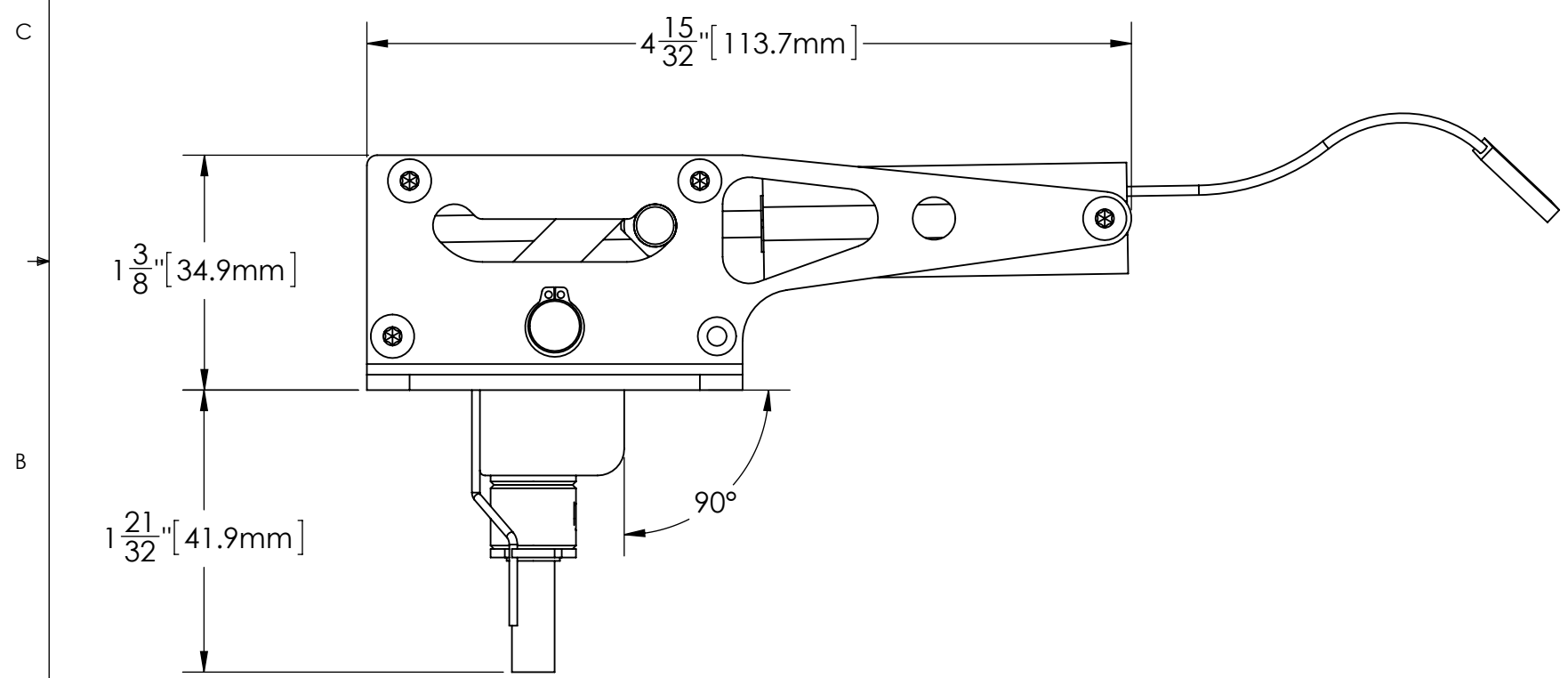
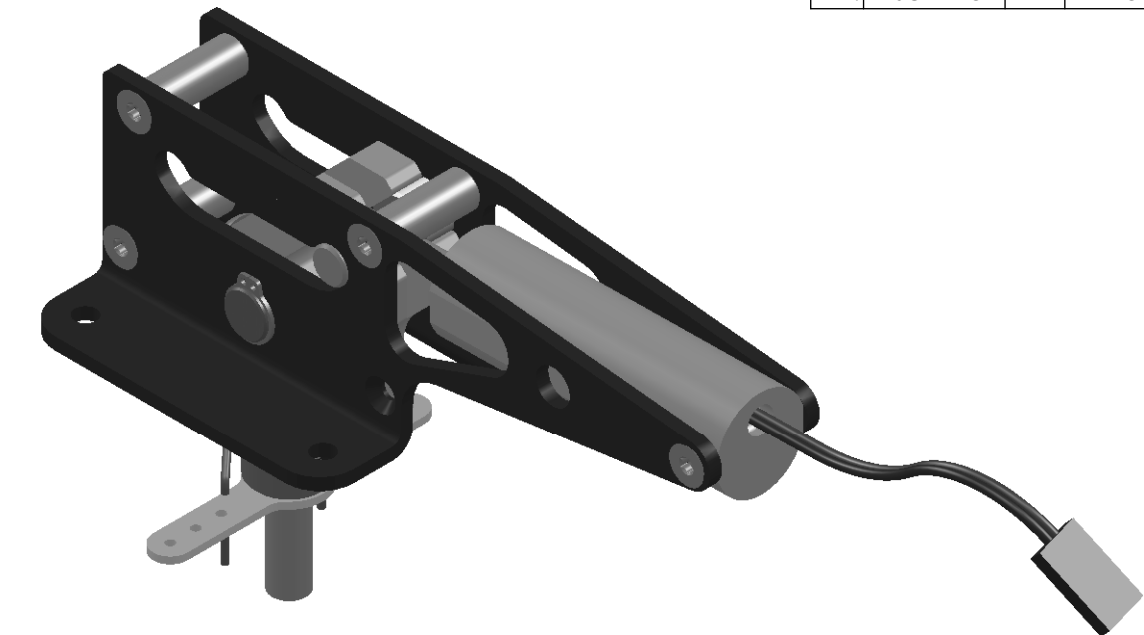
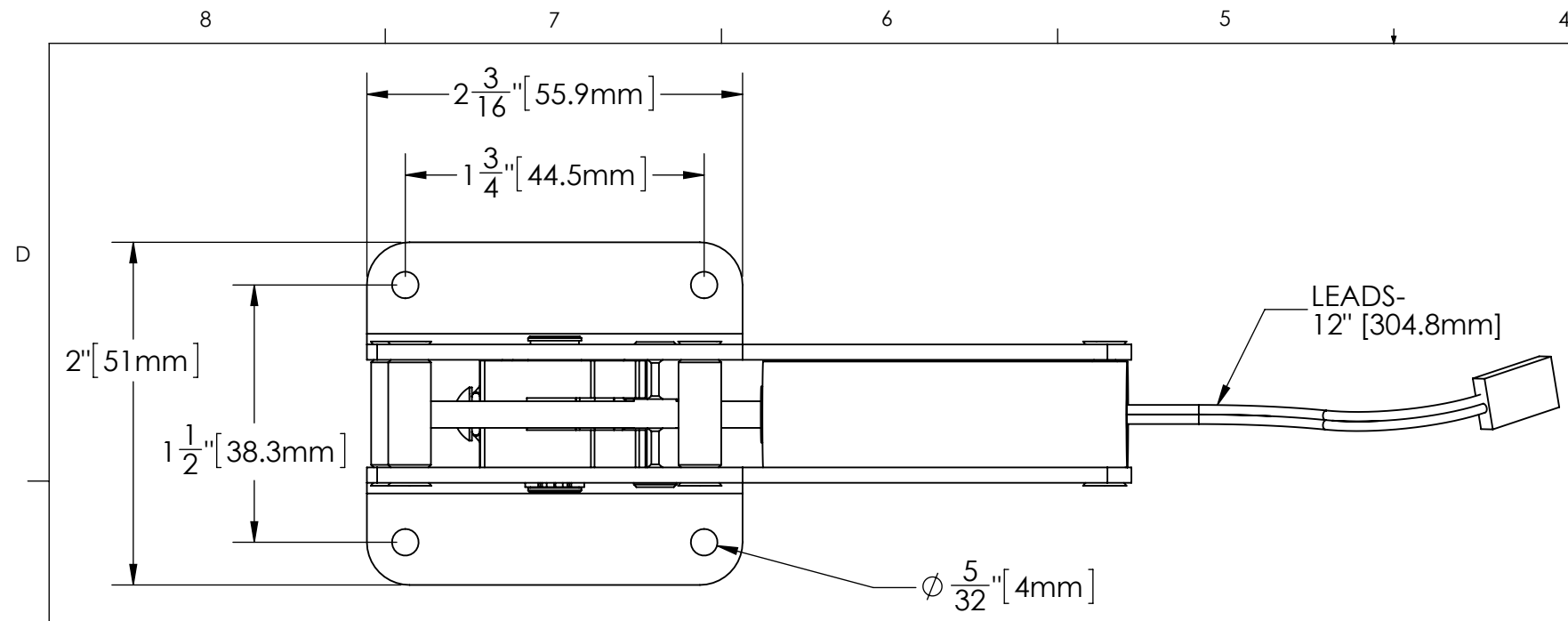

UNITS:
INCH [mm]

ROBART MFG.		
TITLE: DIMENSIONAL DETAIL 638RSE		
SIZE B	DWG. NO. 638RSE DIM	REV -
SCALE: 1:1	WEIGHT:	SHEET 1 OF 1

PROPRIETARY AND CONFIDENTIAL	UNLESS OTHERWISE SPECIFIED:	NAME	DATE
THE INFORMATION CONTAINED IN THIS DRAWING IS THE SOLE PROPERTY OF ROBART MANUFACTURING. ANY REPRODUCTION IN PART OR AS A WHOLE WITHOUT THE WRITTEN PERMISSION OF ROBART MANUFACTURING IS PROHIBITED.	DIMENSIONS ARE IN INCHES	DRAWN	N.MARC
	TOLERANCES:	CHECKED	21JUL14
	FRACTIONAL ± 1/32	MFG APPR.	
	ANGULAR: MACH ± 1° BEND ± 1°	Q.A.	
	TWO PLACE DECIMAL ± 0.01		
	THREE PLACE DECIMAL ± 0.005		
	FOUR PLACE DECIMAL ± 0.0005		