

REVISIONS			
REV.	DESCRIPTION	DATE	APPROVED
1			

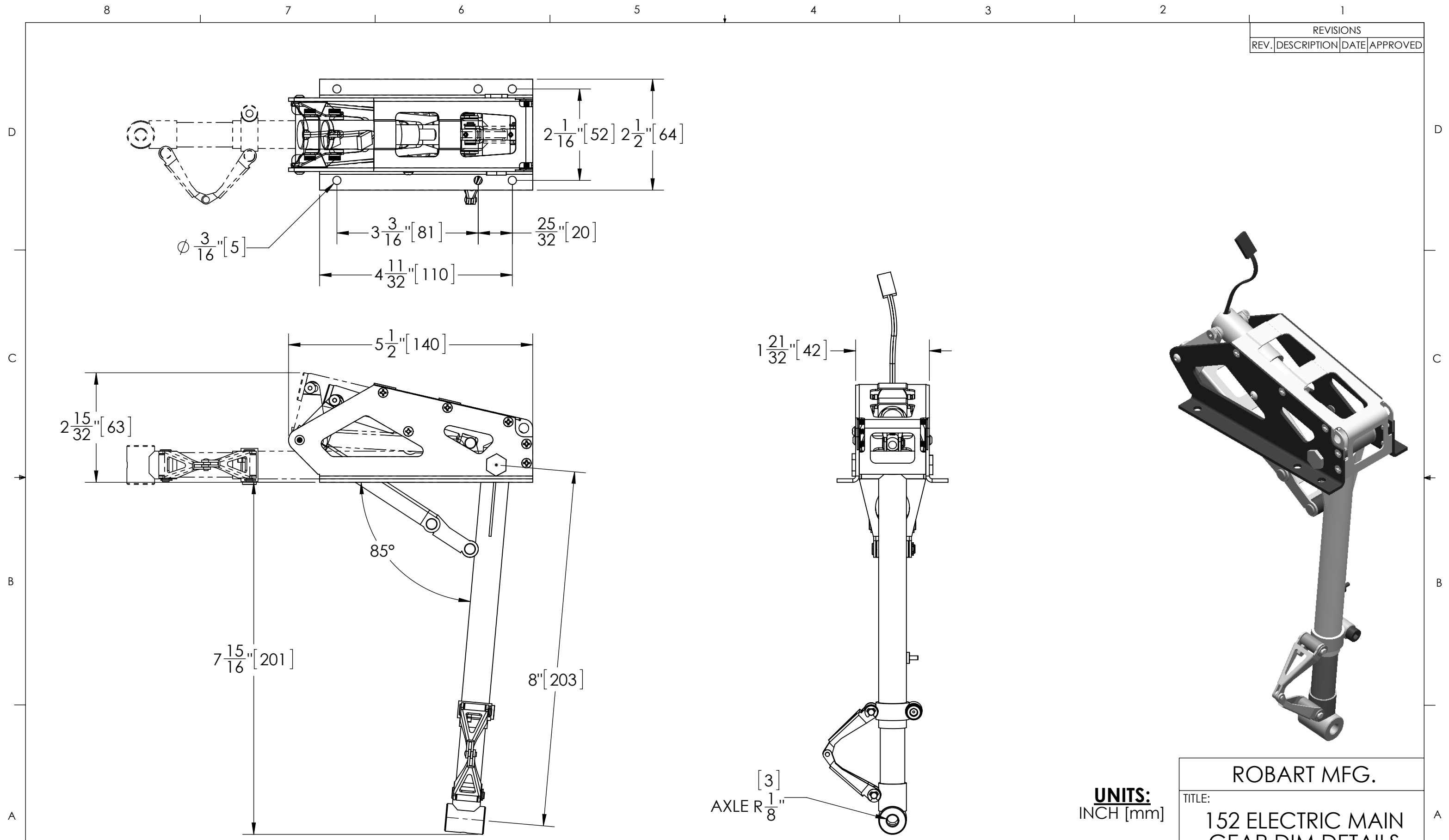

**UNITS:**  
INCH [mm]

ROBART MFG.		
TITLE: 152 ELECTRIC MAIN GEAR DIM DETAILS		
SIZE <b>B</b>	DWG. NO. 152E DIM	REV -
SCALE: 1:2	WEIGHT:	SHEET 1 OF 1

<b>PROPRIETARY AND CONFIDENTIAL</b> THE INFORMATION CONTAINED IN THIS DRAWING IS THE SOLE PROPERTY OF ROBART MANUFACTURING. ANY REPRODUCTION IN PART OR AS A WHOLE WITHOUT THE WRITTEN PERMISSION OF ROBART MANUFACTURING IS PROHIBITED.	UNLESS OTHERWISE SPECIFIED: DIMENSIONS ARE IN INCHES TOLERANCES: FRACTIONAL ± 1/32 ANGULAR: MACH ± 1° BEND ± 1° TWO PLACE DECIMAL ± 0.01 THREE PLACE DECIMAL ± 0.005 FOUR PLACE DECIMAL ± 0.0005	DRAWN	N.MARC	DATE	7JUL14
	CHECKED				
	MFG APPR.				
	Q.A.				