

REVISIONS			
REV.	DESCRIPTION	DATE	APPROVED

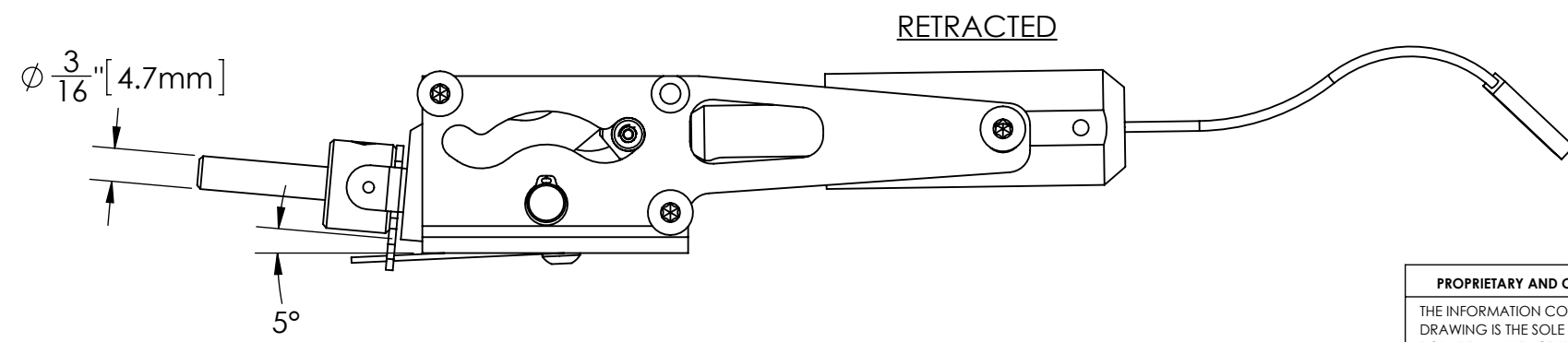
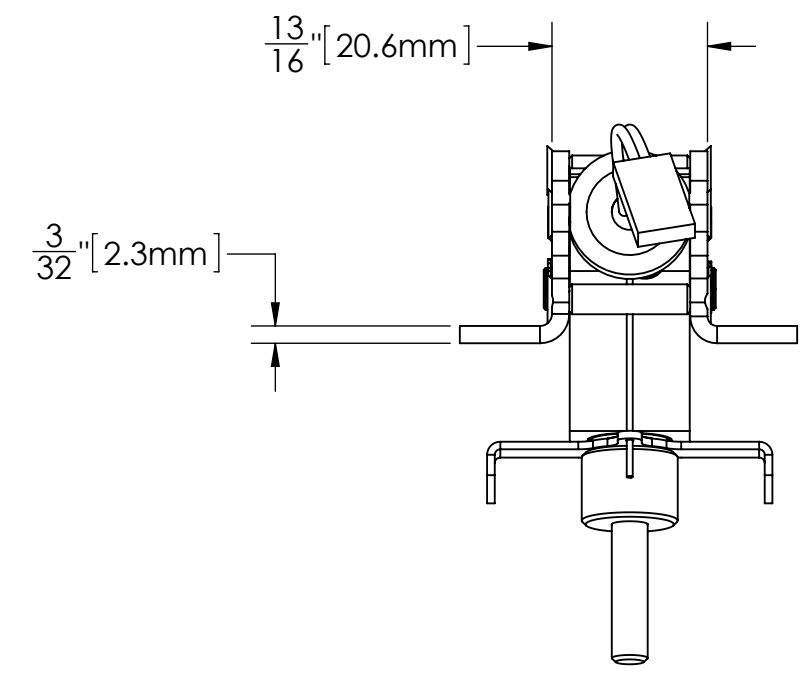
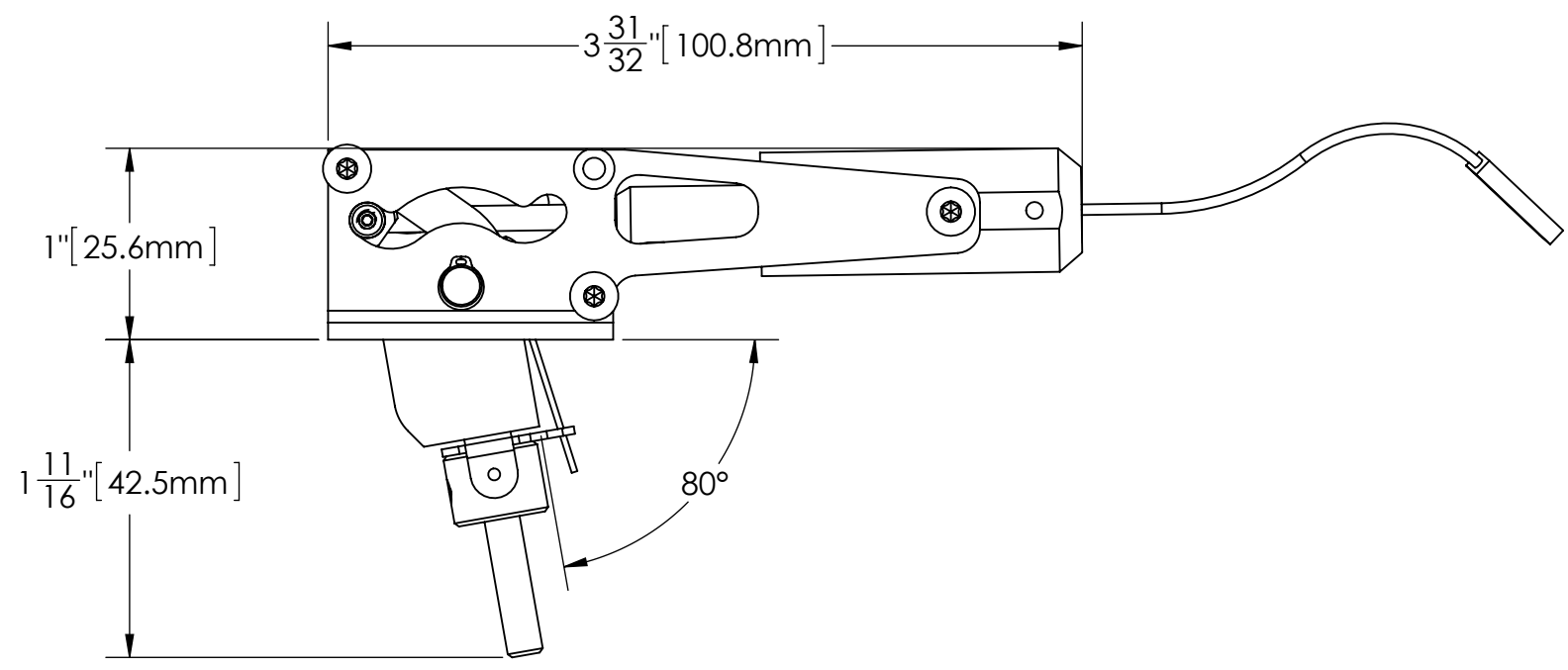
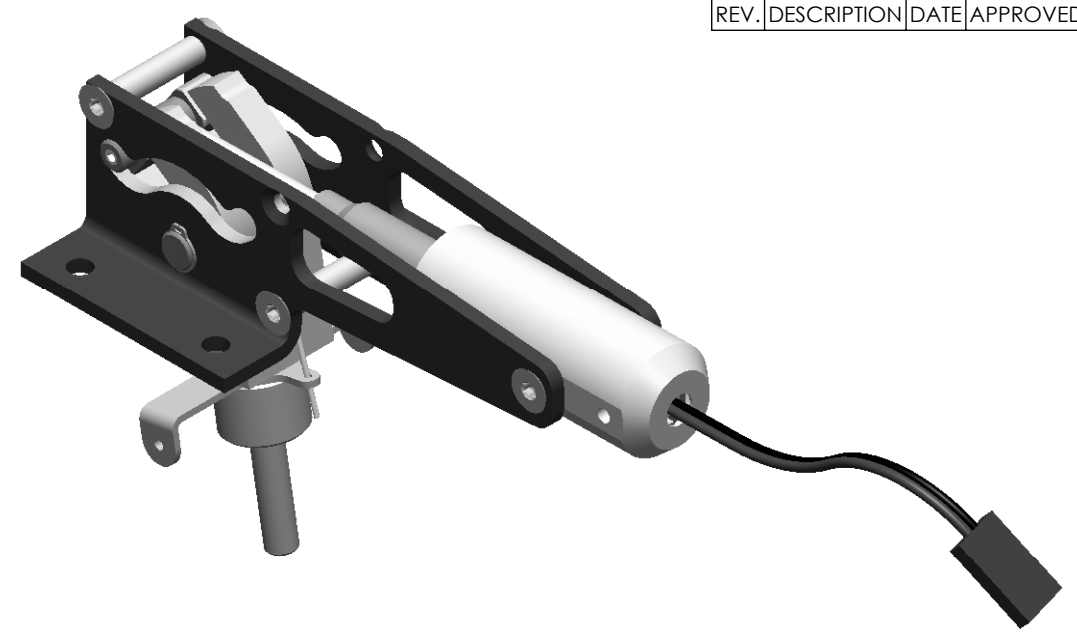
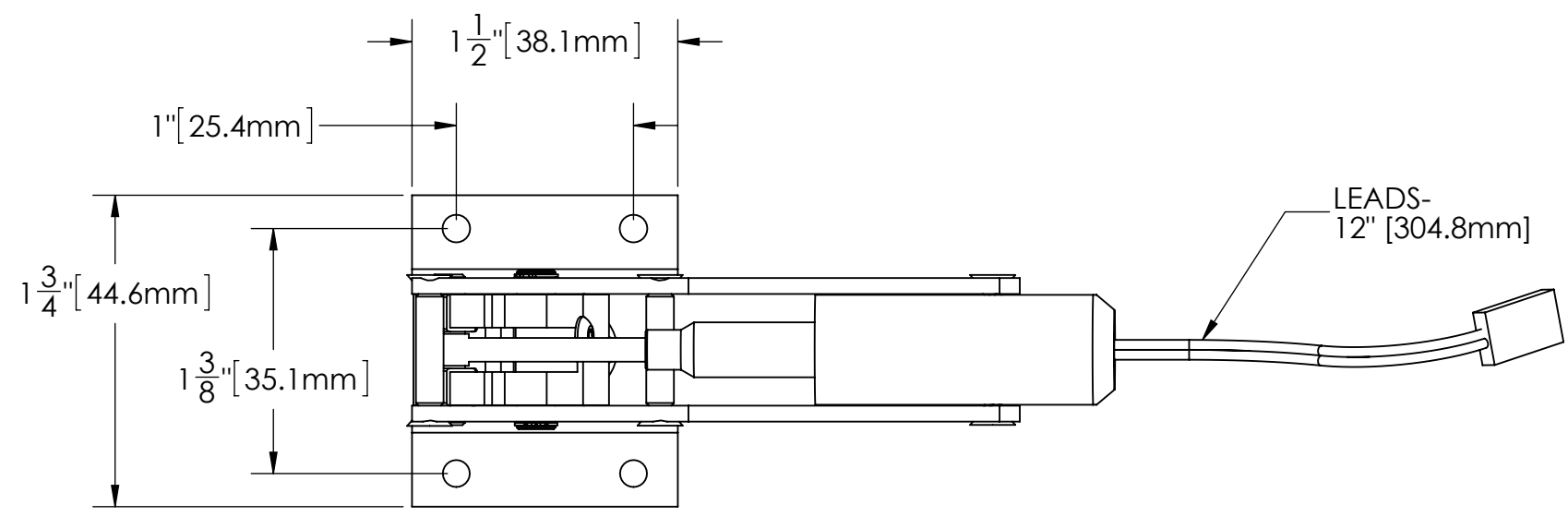

**UNITS:**  
INCH [mm]

ROBART MFG.		
TITLE:		
<b>DIMENSIONAL DETAILS 540RSE</b>		
SIZE	DWG. NO.	REV
<b>B</b>	<b>540RSE DIM</b>	-
SCALE: 1:1	WEIGHT:	SHEET 1 OF 1

PROPRIETARY AND CONFIDENTIAL	UNLESS OTHERWISE SPECIFIED:	NAME	DATE
THE INFORMATION CONTAINED IN THIS DRAWING IS THE SOLE PROPERTY OF ROBART MANUFACTURING. ANY REPRODUCTION IN PART OR AS A WHOLE WITHOUT THE WRITTEN PERMISSION OF ROBART MANUFACTURING IS PROHIBITED.	DIMENSIONS ARE IN INCHES	DRAWN	N.MARC
	TOLERANCES:	CHECKED	21 JUL 14
	FRACTIONAL ± 1/32	MFG APPR.	
	ANGULAR: MACH ± 1° BEND ± 1°	Q.A.	
	TWO PLACE DECIMAL ± 0.01		
	THREE PLACE DECIMAL ± 0.005		
	FOUR PLACE DECIMAL ± 0.0005		