

REVISIONS			
REV.	DESCRIPTION	DATE	APPROVED

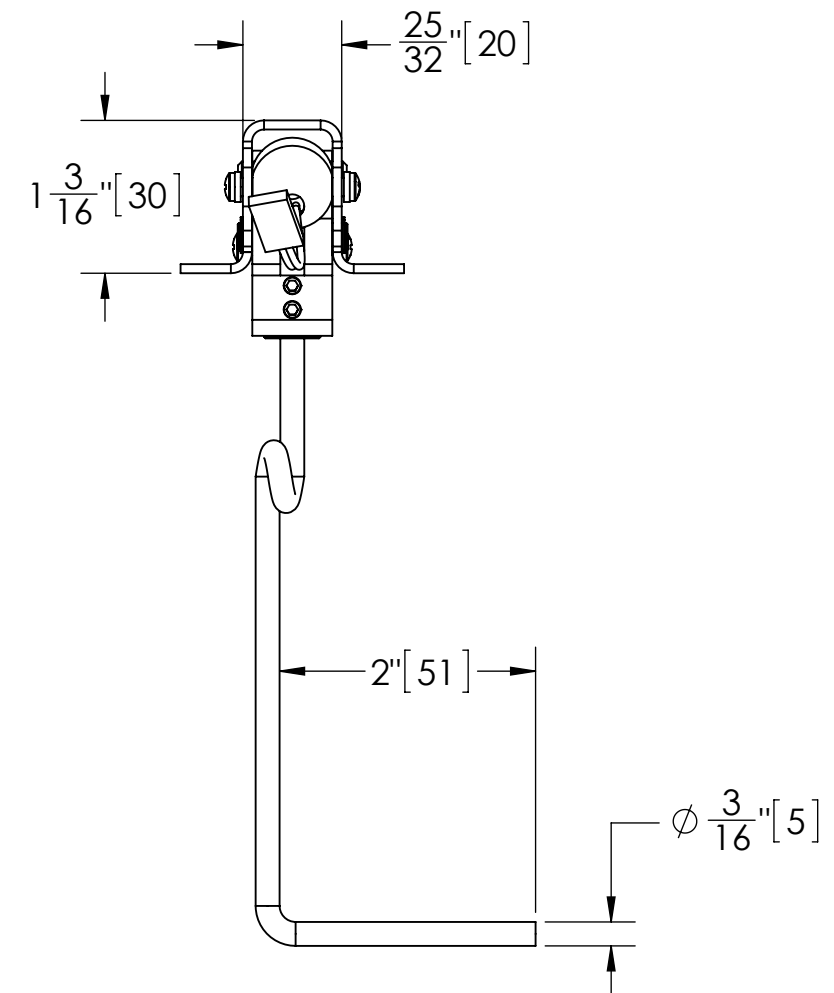
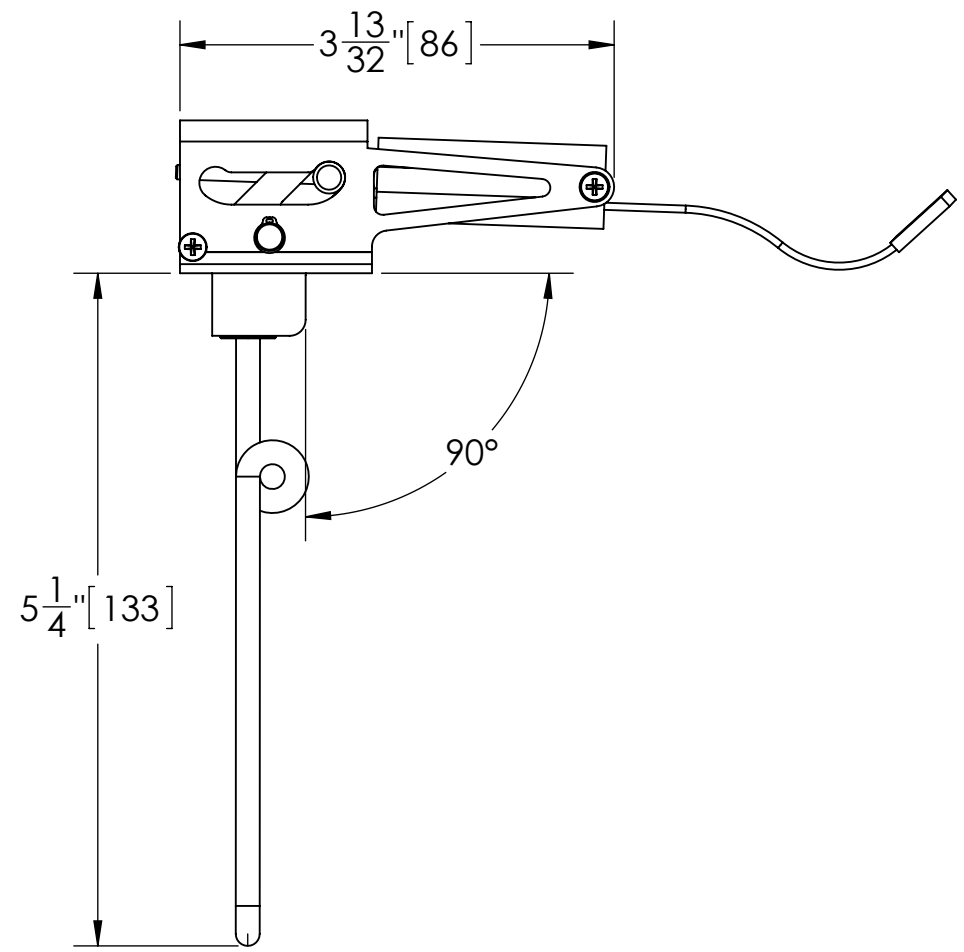
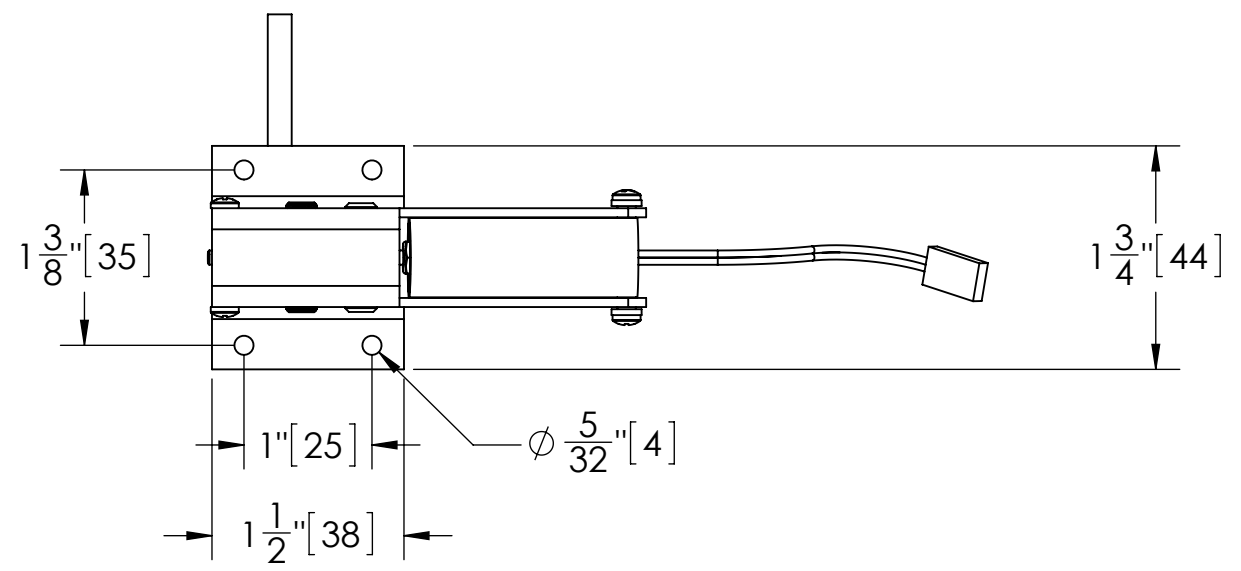

**UNITS:**  
INCH [mm]

ROBART MFG.		
TITLE: 520 DEUCE ELECTRIC MAIN GEAR DIM DETAILS		
SIZE <b>B</b>	DWG. NO. <b>DWEM DIM</b>	REV -
SCALE: 2:3	WEIGHT:	SHEET 1 OF 1

<b>PROPRIETARY AND CONFIDENTIAL</b> THE INFORMATION CONTAINED IN THIS DRAWING IS THE SOLE PROPERTY OF ROBART MANUFACTURING. ANY REPRODUCTION IN PART OR AS A WHOLE WITHOUT THE WRITTEN PERMISSION OF ROBART MANUFACTURING IS PROHIBITED.	UNLESS OTHERWISE SPECIFIED: DIMENSIONS ARE IN INCHES TOLERANCES: FRACTIONAL ± 1/32 ANGULAR: MACH ± 1° BEND ± 1° TWO PLACE DECIMAL ± 0.01 THREE PLACE DECIMAL ± 0.005 FOUR PLACE DECIMAL ± 0.0005	DRAWN	N.MARC	DATE	7JUL14
	CHECKED				
	MFG APPR.				
	Q.A.				

REVISIONS			
REV.	DESCRIPTION	DATE	APPROVED

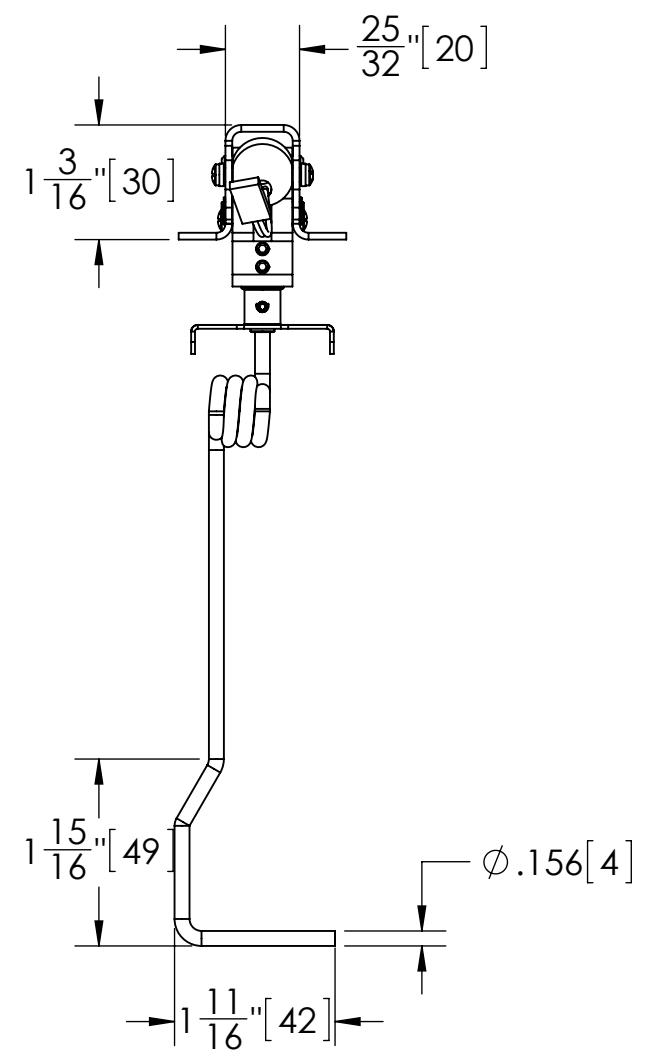
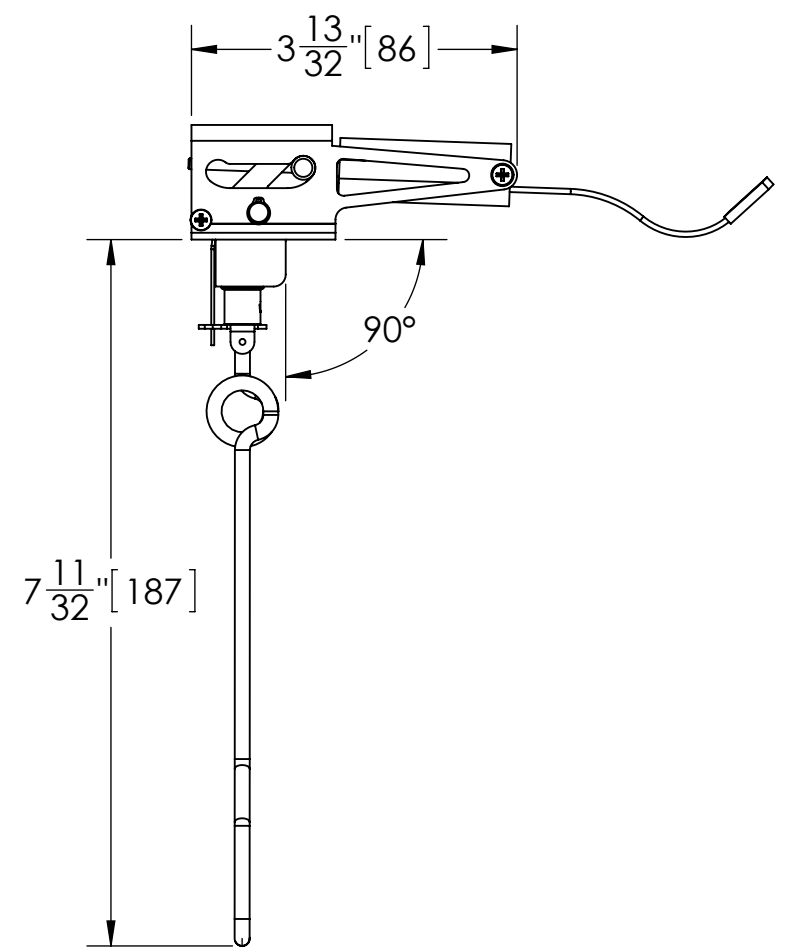
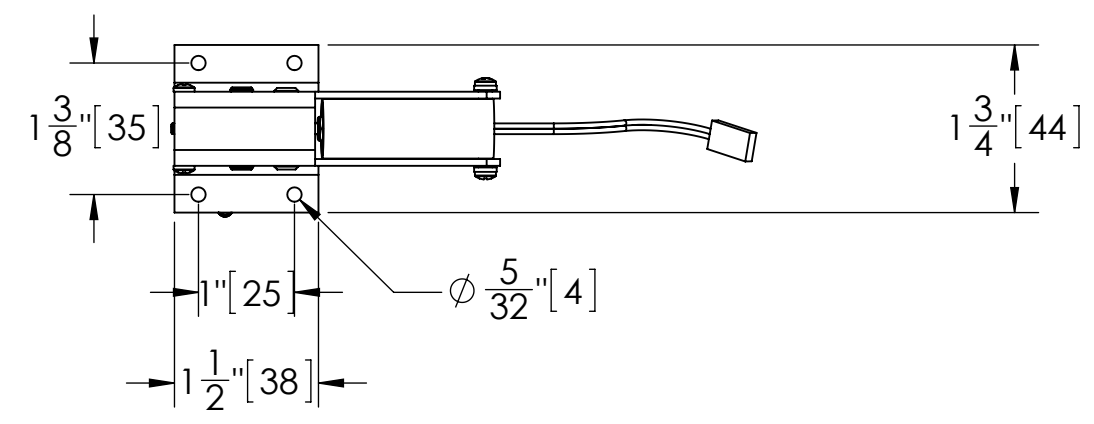

**UNITS:**  
INCH [mm]

ROBART MFG.		
TITLE: 520 DEUCE NOSE ELECTRIC GEAR DIM DETAILS		
SIZE <b>B</b>	DWG. NO. <b>DWEN DIM</b>	REV -
SCALE: 1:2	WEIGHT:	SHEET 1 OF 1

PROPRIETARY AND CONFIDENTIAL	UNLESS OTHERWISE SPECIFIED:	NAME	DATE
THE INFORMATION CONTAINED IN THIS DRAWING IS THE SOLE PROPERTY OF ROBART MANUFACTURING. ANY REPRODUCTION IN PART OR AS A WHOLE WITHOUT THE WRITTEN PERMISSION OF ROBART MANUFACTURING IS PROHIBITED.	DIMENSIONS ARE IN INCHES	DRAWN	N.MARC
	TOLERANCES:	CHECKED	7JUL14
	FRACTIONAL $\pm 1/32$	MFG APPR.	
	ANGULAR: MACH $\pm 1^\circ$ BEND $\pm 1^\circ$	Q.A.	
	TWO PLACE DECIMAL $\pm 0.01$		
	THREE PLACE DECIMAL $\pm 0.005$		
	FOUR PLACE DECIMAL $\pm 0.0005$		